

**VALV**TECHNOLOGIES



# Zero Leakage Valve Solutions

Products & Capabilities



ValvTechnologies'  
focus is to provide  
ZERO LEAKAGE  
VALVE SOLUTIONS

## Solutions

As a global leader in the design and manufacturing of severe service valves, ValvTechnologies has established a worldwide reputation for superior quality and dependability with customers in every industry.

From standard applications to the most sophisticated, ValvTechnologies is committed to providing solutions for customers to manage their processes safely and efficiently. Our approach at ValvTechnologies is based on customer satisfaction, safety, people, process and performance. By equipping highly trained people with the latest technology, ValvTechnologies has created an atmosphere where quality and reliability are built into its products from start to finish. All of ValvTechnologies' valves are designed with customers' requirements in mind and offer proven reliability, superior engineered performance and unique safety features. By focusing on these principles, ValvTechnologies has become an integral part of its customers' asset management strategy.



## Company

ValvTechnologies is a committed partner in providing solutions to manage your process – saving time, money and improving overall system efficiency.

With over twenty-five years of business growth, ValvTechnologies has maintained a culture of innovation by continuously expanding its design, production and technology capabilities. ValvTechnologies provides an unsurpassed level of reliability to customers in the power, oil and gas, mining, hydrocarbon, pulp and paper and various specialty industries. ValvTechnologies' spans across 217,000 square feet (20,160 square meters) of office space and manufacturing which includes research and development, production, complete machining facility, certified welding department and testing. These resources, together with a large inventory of parts and stock valves, allow ValvTechnologies to have complete control of all aspects of the manufacturing process, even for the most demanding projects.

# People

From engineering & design to manufacturing, our employees make the difference.

At ValvTechnologies, our employees are a valuable asset. Made up of functional teams that focus on customer service, safety, product development, quality management, assembly and testing; our staff is committed to continually developing innovative designs, production and technology capabilities. With a full staff of professional engineers, a technical sales team and certified service technicians, ValvTechnologies is more than a manufacturer – we are a partner for providing superior solutions to your process needs.



# Process

At ValvTechnologies, our processes and procedures ensure that our valves exceed our customers' needs.

From raw material to the finished product, we are constantly looking for methods to apply innovative technologies to our process. While many valve manufacturers are focused on cutting corners to save costs, we remain true to our core design principles relentlessly pursuing product and process improvements that in the long term provide measurable benefits for our customers. ValvTechnologies' in-house research and design capabilities include:

- High temperature testing
- High pressure testing
- Load/force testing
- Torque testing
- Cycle testing
- Fugitive emissions testing
- Data acquisition

We also work directly with customers to develop solutions that meet unique process requirements and specialty applications.

# Performance



## ValvTechnologies sets the standard for zero leakage valve solutions.

At ValvTechnologies, we are totally committed to quality. We measure our performance against the standards set in our Integrated Quality Program. Our Quality Assurance department diligently pursues opportunities for improvement, while the entire organization takes ownership of the quality program. In this way, we can improve our processes while increasing manufacturing efficiency.

For a complete list of ValvTechnologies certifications, please visit [www.valv.com](http://www.valv.com).

## Factory Authorized Service Centers

ValvTechnologies is committed to helping our global network of customers maintain peak valve performance. ValvTechnologies has multiple authorized service centers located around the world that are available **24 hours a day, 7 days a week** to assist with valve installation, commissioning, troubleshooting and other maintenance that may be needed.

To locate a factory authorized service center near you, please visit [www.valv.com](http://www.valv.com).

### Quality policy

ValvTechnologies will provide superior, defect-free products and services to our customers that meet or exceed all legal and regulatory requirements.

Continual improvement will be the basis for enhanced effectiveness by meeting our identified Key Process Indicators (KPI).

# Applications

ValvTechnologies provides field proven solutions for severe service applications.

ValvTechnologies' valves are built to withstand the most severe applications. High temperature, high pressure, high cycling, abrasive, corrosive and caustic media have all been considered in the design of our product line.



## Nuclear Generation

- Boiler feedwater
- Circulating water system
- Component cooling
- Condensate extraction
- Condensate cooling water
- Emergency feedwater
- Fire protection system
- HP safety injection
- HP & LP heater drains
- Heat exchanger vent & drains
- Main steam system isolation, drain & vent
- Power operated relief valve (PORV)
- Pressurizer drain & vent
- Rad waste system
- Reactor coolant pump drain & vent
- Reactor head vents
- Reactor water cooling vents & drains
- Safety injection system
- Secondary system isolation, drain & vent
- Service water system isolation
- Steam generator system
- Turbine by-pass
- Turbine drain & vent
- Fukushima tie ins
- Reliable hardened vents

## Fossil Fuel

- Above & below seat drains
- Ash handling
- Attemporator spray control
- Boiler drains
- Boiler feed pump isolation
- Continuous boiler blowdown
- Electronic relief
- Feedwater heater drains
- Feedwater isolation
- Instrument isolation
- Main steam stop
- Recirculation
- Seal steam regulators
- Sight / gauge glass drains
- Soot blower regulators
- Startup vents
- Steam dump
- Turbine bypass systems
- Turbine drain

## Upstream Oil & Gas

- Wellhead choke isolation
- HIPPS
- Emergency shutdown
- Compressor recycle & isolation
- Sour gas isolation & control
- Steam, water & gas injection
- Steam chokes
- SAG-D isolation
- Pig launcher & receiver
- Mud drilling isolation & check
- Lean & rich amine isolation
- Molecular sieve regeneration isolation
- Molecular sieve absorber isolation
- First & second stage separator isolation





## Downstream & Chemical Processing

### Coking (Delayed & Flexi)

- Switching
- Feed isolation
- Overhead vapor line
- Cutting water isolation

### Fluidized Catalytic Cracking

- Catalyst handling
- Slurry isolation & control steam

### Ethylene

- Steam decoke isolation
- Furnace isolation
- Steam vent
- Quench oil isolation & control

### Polyethylene

- Isolation
- High cycle (PTO)
- Reactor block

### Heavy Oil Upgrading & Hydrocracking (H-Oil & LC Fining)

- Catalyst addition & withdrawal
- Filter & pump isolation
- Overhead vapor isolation & control
- High delta-P isolation & control

### Reforming (CCR)

- Lockhopper
- Isolation

## Mining & Minerals Processing

### High Pressure Slurry Transportation Systems

- Pump discharge isolation
- Pipeline isolation stations
- Pipeline choke stations
- Rupture disk isolation
- Instrument isolation

### Autoclaves

- Vessel feed & discharge
- Acid injection
- Gas injection
- Steam injection

### Mineral Concentrators

- Thickener underflow
- Discharge isolation
- Filter press manifold isolation
- Slurry transfer systems
- PRV isolation

### Waste Disposal

- Tailings pipelines
- Paste backfill

## Pulp & Paper

- Boiler vent & drain
- Liquor isolation & control
- Rapid drain
- Steam isolation
- Sky vents
- Dryer pressure control
- Digester steam control
- Lime mud isolation & control



# V1 Series

The Flagship of the ValvTechnologies Product Line.

The ValvTechnologies' design features are the implementation of extensive industry experience.

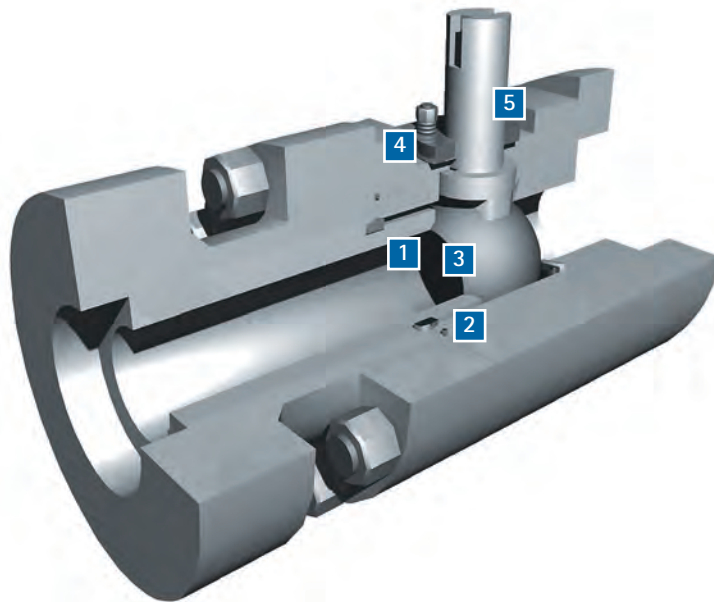

## 1 Integral Metal Seat.

With our patented HVOF ceramet coating technology, the integral seat in ValvTechnologies' valves is resistant to the attack of abrasive magnetite and ferrous oxides that may be seen in the steam flow.

## 2 Body Seal Ring.

ValvTechnologies employs a field proven seal ring technology to ensure sealing under all operating conditions, up to 1400° F. The body seal ring is loaded at a pressure higher than 20,000 psi. In addition, valves sized 3" and above contain a secondary Grafoil seal to further guarantee reliability.

## 3 Patented Coating Process.

The sealing surfaces are overlaid with Tungsten or Chromium Carbide using our HVOF ceramet coating process. These surfaces have a hardness of 68 - 72 Rc to provide uninterrupted operation in the most severe conditions.

## 4 Live Loaded Gland Area.

The V1 Series gland packing design features a four stud, live-loaded assembly designed for heavy industrial applications. The packing material is high purity Grafoil® surrounded by Carbon Fiber / Inconel anti-extrusion rings. The six Bellville springs (per stud) provide constant load pressure through extreme thermal shocks and prevent wear leaks in high cycle service.

## 5 Blow-out Proof Stem.

ValvTechnologies design utilizes a one piece, hard-faced, blow-out proof stem that is inserted through the inside of the body cavity eliminating the possibility of blow-out through the gland area. There are no pins, collars or other devices used to retain the stem in the valve body.





## V1-1

Forged, High Pressure Valves.  
Four Year, Zero Leakage Guarantee.

- ASME Class 900 - 4500
- 1/4" - 4"

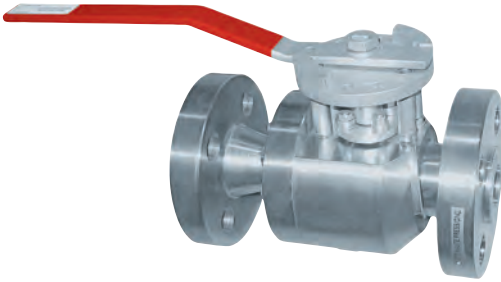

## V1-2

Flanged, Low Pressure Valves.  
Four Year, Zero Leakage Guarantee.

- ASME Class 150 - 600
- 1/2" - 36"



## V1-3

Small Bore, Low Pressure, Investment Cast Valves.  
Four Year, Zero Leakage Guarantee.

- ASME Class 150 - 600
- 1/2" - 2"



## V1-4

Large Bore, High Pressure Valves.  
Four Year, Zero Leakage Guarantee.

- ASME Class 900 - 4500
- 4" - 36"

# Zero Leakage Valve Solutions

## PSG

### Parallel Slide Gate. Bi-directional, Zero Leakage Isolation.

ValvTechnologies' Parallel Slide Gate valve (PSG) addresses the need for true in-line valve reparability in large diameter, high energy piping systems. Specifically designed for steam and feedwater applications, the PSG provides bi-directional, zero leakage using the HVOF ceramet coating system.



- ASME Class 300 - 4500
- 6" - 36"
- Position seated easily automated
- In-line repairable
- Four year, zero leakage guarantee

## ERV

### Electronic Relief Valve. For Protection of Conventional Safety Relief Valves.

ValvTechnologies' Electronic Relief Valve (ERV) fulfills the need for a zero-leakage, pilot-operated relief valve. The ERV package combines ValvTechnologies' zero leakage isolation valve with electronic controls to monitor and regulate system pressure. Whether in a capacity relieving function requiring the ASME V-Stamp or simply an overpressure protection application, the ERV provides reliable protection for standard safety valves in many industries. ValvTechnologies can also provide an integral isolation valve, eliminating the need for costly field welding.



- ASME Class 150 - 4500
- 1/2" - 12"
- ASME Sec. I, V-Stamp Capacity Certified
- Integral isolation valve available
- Easily adapted to existing controls
- Four year, zero leakage guarantee

## ERV Control Box

### Control Box for ValvTechnologies ERV.

ValvTechnologies' new light-weight compact control box operates in much the same way as the old but integrates many improvements including better environmental performance, simplified wiring and control, set point programmability and fault indication.



- Enclosure: NEMA 4X, stainless steel
- Auto/Manual Function: Automatic + DCS Auto
- DCS Function: Dry contact
- Fault indication: Yellow LED
- Pressure transmitter: 4-20mA
- Calibrated by PLC interface

## XACTROL®

**Characterized Trim.  
Leak Free Isolation and Control in One.**

The XACTROL® product group unites ValvTechnologies' zero-leakage technology with special designs that allow rotary modulating control. From the Mark I's design that features a characterized upstream seat to the Mark III's precision engineered stacked disks, the XACTROL® allows the customer to combine precise flow control with tight shut-off. The XACTROL® is typically used in applications where minimum flow and relatively high differential pressures are required.



- ASME Class 150 - 2500
- 1/2" - 36"
- Integral, characterized downstream seat
- Upstream disc inserts for modulation

## Turbine Bypass System

**Combined Cycle Plant Solution.  
Facilitates Fast Start-up.**

The ValvTechnologies Turbine Bypass System (TBS) is designed for the new generation of combined-cycle power plants. It combines the XACTROL® control valve design with a state-of-the-art desuperheating control system. The system allows the plant operator to keep the gas turbine and the HRSG online in the event of a steam turbine trip. The TBS also facilitates fast CT and HRSG start-ups in peaking power plants and allows these plants to operate at turndown conditions, far below the levels that can be achieved with standard governor systems.



# Trunnion Ball Valves

The Next Generation in Trunnion Technology.

The NEXTECH® trunnion design provides a severe service solution for tough, high cycling applications.

## NEXTECH® "R" Series

Low Pressure Trunnion.  
Low Torque, Bi-directional Shut-off.

The NexTech® "R" Series (regular series) valves are a low-cost valve ready for immediate delivery. Engineered with the same quality standards of all ValvTechnologies products, the NexTech® "R" Series valve has been produced to lower costs and is stocked and ready to ship. While the "R" Series is our base stock model, there is nothing basic about its design and performance. This valve design represents the state-of-the-art in severe service metal seated ball valve technology.



- ASME Class 300 - 600, 2" - 6"
- ASME Class 300, 8"
- Low pressure, trunnion-mounted

## NEXTECH® "E" Series

High Pressure Trunnion.  
Block & Bleed, Bi-directional Shut-off.

The NexTech® "E" Series (enhanced series) represents a true engineered to spec, specialty valve with materials selected to meet the needs of the most demanding applications. These valves are designed and configured to handle corrosive, high temperature and high solids applications requiring tight shut-off.

- 2" - 24"
- ASME 300# - 900#

The TRUNTECH™ trunnion design provides provide long life in abrasive and erosive conditions.

## TRUNTECH™

Designed to API-6D and API-6A.

ValvTechnologies' TrunTech™ is designed to address the severe service demands of the upstream and midstream oil and gas Industries. Its protected seat seals design provides long life and tight shut-off in abrasive / erosive conditions and meeting stringent fugitive emission requirements.



- ASME Class 150 - 2500
- API 5000 - 15000
- Sized per API 6A and 6D

# Isolation Valves for Coking Service

The delayed coker process is one of the most hostile environments in the refinery due to the abrasive and erosive properties of the coke by-product and crucial to a refinery's profitability. Valves are cycled frequently and failure can lead to a complete shutdown of a unit, resulting in large process and financial costs. Optimizing valve life-cycle is critical to operational efficiency.

## Coking Valves

**Avoid Unscheduled Downtime and Lost Production.**

The ValvTechnologies' isolation valve for coking services provides process improvements and reliability through turn-arounds. The simple, yet wear and erosion-resistant, design ensures reduced maintenance time and costs for customers in these severe service applications.



- ASME Class 300 - 1500
- 1" - 36"

## Switch Valves

**Delayed Coker Service Solution.  
Mechanically-Loaded Design that  
Eliminates Steam Bellows.**

Improve reliability, decrease unscheduled downtime and production losses with ValvTechnologies' switch valve. Enjoy a decade or more between major maintenance requirements and peace-of-mind through tight shut-off with preventative maintenance continuous purge systems.



- ANSI 900 with 600 connections
- 8" - 18"

# Specialty Valve & Actuator Solutions

## VALVXPRESS™

Quality and dependability in one package – guaranteed

VALVXPRESS™ – for customers who demand quick delivery of a zero-leakage automated valve solution for severe service water and steam applications. The package includes the superior quality of the V1-1 valve and ValvTechnologies actuator, backed with the best four-year guarantee in the industry. VALVXPRESS™ pre-engineered, automated packages are compact, robust and ready to ship.



Four-year guarantee on valve and actuator automation packages.

Available for quick delivery.

Pre-engineered package includes:

- 1/2" thru 4" metal-seated V1-1 ball valve
- Socket weld and butt weld end connections
- A105, F22, F91 body materials
- 2500# and 4500# pressure classes
- Valve operating conditions to 1400°F (760°C)
- High-cycle pneumatic rack and pinion actuator
- High-cycle mounting hardware
- Limit switch with position indicator – 2-SPDT, quick set cam, IP67, NEMA 4/4X
- NAMUR solenoid – 110V/120V, 230V, 24VDC coils
- Filter/regulator with gauge
- Retainer prevents stem driving into ball

## VALVXPRESS™ Actuator

The actuators utilize a rack and pinion design which provides constant torque output in a compact package. The torque output is proportional to the air supply pressure. Twin horizontally opposed cylinders incorporate piston guides to ensure engagement between the rack and pinion. Double acting and spring return models are of comparable compact design.

- Hard anodized body with high-temperature Viton® seals
- Maximum working pressure 142 psi / 10 bar
- Maximum working temperature 320°F / 160°C



# Specialty Valve Solutions

## ABRASOCHECK®

### High Pressure Positive Displacement Pump Slurry Check Valve.

ValvTechnologies' ABRASOCHECK® slurry check valve is an upgrade of a product that has been used successfully in service for more than 30 years at the Savage River Iron Concentrate Pumping Plant in Tasmania. ValvTechnologies has re-engineered and improved the design of this product to be in line with our own technology for materials, coatings and manufacturing improvements. The combination of the ValvTechnologies' ABRASOCHECK® slurry check valve and the ValvTechnologies ABRASOCHECK® slurry ball valve provides **zero leakage isolation** for maintenance of positive displacement pumps.



- ASME Class 600 - 1500
- 4" - 24"
- Zero leakage isolation

## ABRASOTECH®

### Slurry Transport Solution. Erosion & Corrosion Resistant.

The ValvTechnologies ABRASOTECH® valve is the result of extensive experience in providing reliable valves for the transportation of slurries in cross country pipelines. With an installed base of over 7,000 slurry service valves worldwide, ValvTechnologies is the established leader in these applications. The ABRASOTECH® valve is offered in carbon and stainless steel materials. The valves' internals can be protected against erosion and corrosion with the use of HVOF cerammet coating and metallic or urethane liners.



- ASME Class 150 - 2500
- 1/2" - 36"

## Acid Injection Isolation

Designed for HPAL Service.  
Emergency Shutdown Valve.

The ValvTechnologies Acid Injection Isolation Valve is a unique product created and designed for the isolation and emergency shutdown of HPAL autoclave acid injection systems. This valve uses ceramic seats, plasma coatings and exotic metals to provide plant security in the harshest of process conditions.



- ASME Class 600
- 1/2" - 4"
- Field proven design

## 3-Way Valve

Flow Diversion & Isolation.  
Repeatable Tight Shut-off.

ValvTechnologies' metal seated 3-way valves are designed for the most severe applications where flow diversion is combined with the need for repeatable tight shut-off. The 3-way valve is available in 'T' and 'Y' configurations and in multiple combinations of body materials, trims and end connections.



- ASME Class 150 - 4500
- Temperatures up to 1400° F / 760° C
- Tight shut-off



## Double Ball Valve

**Bi-directional Isolation.**  
**Back Pressure Protection.**

Double Ball Valves (DB-2) fulfill the demanding needs for industrial applications where zero leakage isolation is required in bi-directional or double block-and-bleed valves. This valve is particularly useful when solids and high temperatures are present and can also be used in cases where space is limited. Two sealing units are required and one actuation device is preferred. The bi-directional version has the added advantage of back pressure protection. Even in very high pressure applications, this design prevents the sealing surfaces from separating.

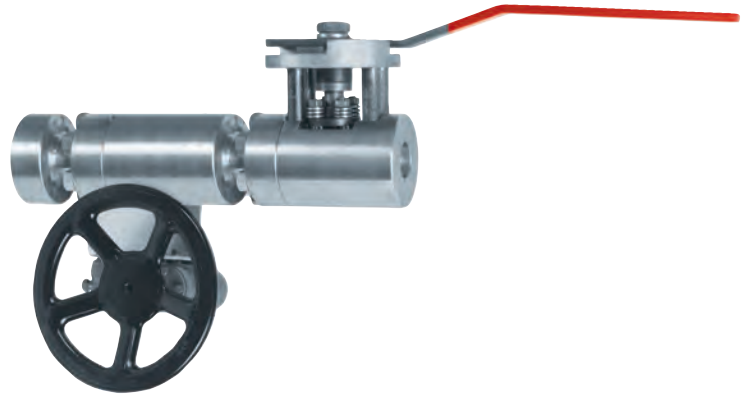

- ASME Class 150 - 4500
- Temperatures up to 1600° F / 870° C
- One actuation device

## Integral Block & Bleed

**Two Isolation Points.**  
**Class V Shut-off.**

ValvTechnologies' Integral, Double Block & Bleed Valve is designed to provide unidirectional zero leakage shut-off, with **two isolation points in a single valve body**. Tight shut-off is confirmed by opening the bleed valve – guaranteeing a safe working environment downstream. Designed for and tested in steam service, the Integral Block & Bleed is available in a wide range of sizes, materials and end connections. It is easily automated with pneumatic, electric or hydraulic actuators – according to the customer's control specifications.



- ASME Class 150 - 1500
- 2" - 36"
- Designed & tested for steam service

# Specialty Solutions

## RHIONITE® Hardfacing

Provides Bottom-line Cost Savings.  
Wears five to seven times longer than bare metal in process applications.

The Rhinoite® process uses a specially formulated tungsten carbide carbide pellet made to a predetermined chemistry. It is applied by a patented metal inert gas (MIG) welding process onto a large variety of base metals using various types of weld wires. The process is a two layer application.

The process can be adapted to all service environments, in any wear application: erosion, corrosion, adhesion and high temperature applications (2200°F). ValvTechnologies Rhinoite® hardfacing has been a proven leader of hard metal overlay on elbows, t-sections and choke tubes in chemical plants and refineries for the past six years (with zero failures). The Rhinoite® hardfacing weld process focuses on minimizing loss of production time by wearing five to seven times longer than bare metal. The Rhinoite® hardfacing overlays can be completely refurbished after years of service, reducing overall material and maintenance costs.





## Total Valve Management (TVM®) Program

Cycle isolation eliminates energy losses attributable to poorly performing or leaking steam, water cycle isolation valves.

ValvTechnologies encourages end users to apply the principles of Asset Management to their installed valve population. The ValvTechnologies Total Valve Management (TVM®) program, also known as cycle isolation, utilizes next generation acoustic monitoring instruments to help customers monitor valve performance. These tools allow predictive and preventative maintenance programs to be fine tuned for very large or very small valve populations. Providing cycle isolation services can be as simple as performing a valve survey, or as comprehensive as the management of all valve work during your next outage – from erecting scaffolds to repairing, installing, welding and stress relieving.

### ValvTechnologies' Program Highlights:

- **1 - 4% in plant system efficiency increase**
- Best-in-class valve leakage diagnostics
- Predictive maintenance savings vs. scheduled maintenance activities
- Overall reduction in maintenance costs
- Target only high-value, fast-payback repairs and replacements
- Ease of execution
- Fast results with minimum effort
- Non-intrusive to plant operations

Most plants will see a thermal efficiency (heat rate) system improvement of 1-4%

# Zero Leakage Valve Solutions

## Products & Capabilities

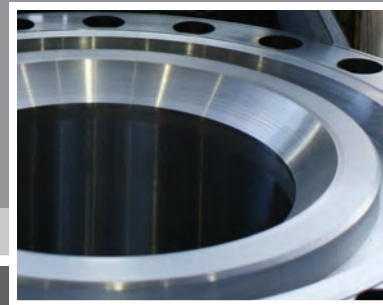

### Worldwide Office Locations

#### Headquarters & Manufacturing

ValvTechnologies, Inc.  
5904 Bingle Road  
Houston, Texas 77092 U.S.A.  
Telephone +1 713 860 0400  
Fax +1 713 860 0499  
[info@valv.com](mailto:info@valv.com)

To locate a distributor or satellite office near you, visit us online at: [www.valv.com](http://www.valv.com)

To contact sales anywhere in the world, email [sales@valv.com](mailto:sales@valv.com)

**Peru**  
Lima  
[peru@valv.com](mailto:peru@valv.com)

**Brazil**  
São Paulo  
[brazil@valv.com](mailto:brazil@valv.com)

**United Kingdom**  
Stockton-on-Tees  
[europa@valv.com](mailto:europa@valv.com)

**Australia**  
Brisbane  
[australia@valv.com](mailto:australia@valv.com)

**China**  
Shanghai  
[china@valv.com](mailto:china@valv.com)

**China**  
Chengdu  
[china@valv.com](mailto:china@valv.com)

**China**  
Beijing  
[china@valv.com](mailto:china@valv.com)

**Eastern Europe**  
Warsaw  
[poland@valv.com](mailto:poland@valv.com)

**Middle East**  
Dubai  
[middle.east@valv.com](mailto:middle.east@valv.com)

**India**  
Chennai  
[india@valv.com](mailto:india@valv.com)

**Japan/Korea**  
Seoul  
[korea@valv.com](mailto:korea@valv.com)

**Spain**  
Madrid  
[spain@valv.com](mailto:spain@valv.com)